

NAVIGATION LIGHT GEOMAR MK-LI SINGLE



APPLICATION

- For all sea going vessels with a length of 20 meters or more.
- According to International Regulations for Preventing Collisions at Sea. 1972 (72 COLREGS – IMO72)

TECHNICAL FEATURES

- Polycarbonate reinforced with fibreglass. Mat black.
- Lens: Polycarbonate Fresnel lens. Shock resistant.
- Fully resistant to sea environment. Non magnetic.
- Lamp easy to change. Socket: B 22
- 2 meters special navy cable included
- Optional: IP67 connection box
- Lateral mounting
- Weight: 1,25 kg
- IP 56
- Delivery of custom made lights upon request.

Starboard	Port	Masthead	Stern	Towing	Signalling	Manoeuvring	Suez	Steering
112,5° 3nm	112,5° 3nm	225° 6nm	135° 3nm	135° 3nm	360° 3nm	360° 6nm	135° 3nm	30° >2nm

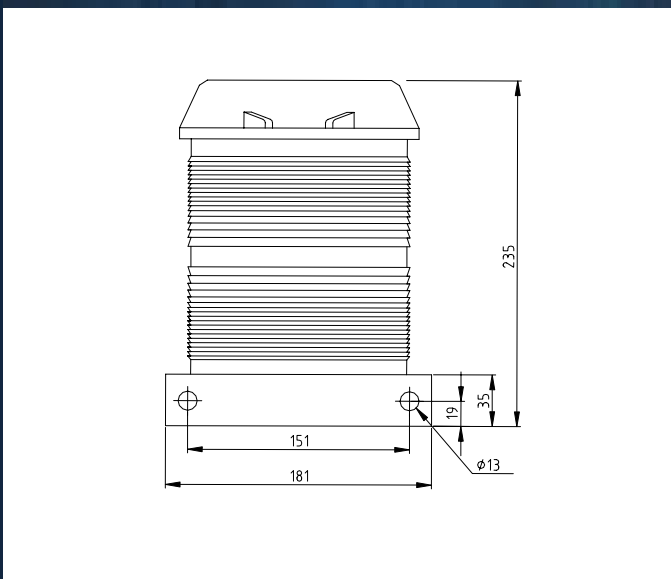

- Input Voltage: 24V, 110V, 220V
- Power Consumption: 50W, 55W, 85W



ISO 9001:2000 certified
Nav. Lights certified by Spanish Maritime Directorate
in compliance with IMO regulations

NAVIGATION LIGHT GEOMAR MK-LII DOUBLE



APPLICATION

- For all sea going vessels with a length of 20 meters or more.
- According to International Regulations for Preventing Collisions at Sea.
- 1972 (72 COLREGS – IMO72)

TECHNICAL FEATURES

- Polycarbonate reinforced with fibreglass. Mat black.
- Lens: Polycarbonate Fresnel lens. Shock resistant.
- Fully resistant to sea environment. Non magnetic.
- Lamp easy to change. Socket: B 22
- 2 meters special navy cable included
- Optional: IP67 connection box
- Lateral mounting
- Weight: 1,25 kg
- IP 56
- Delivery of custom made lights upon request.

Starboard	Port	Masthead	Stern	Towing	Signalling	Manoeuvring	Suez
112,5° 3nm	112,5° 3nm	225° 6nm	135° 3nm	135° 3nm	360° 3nm	360° 6nm	135° 3nm

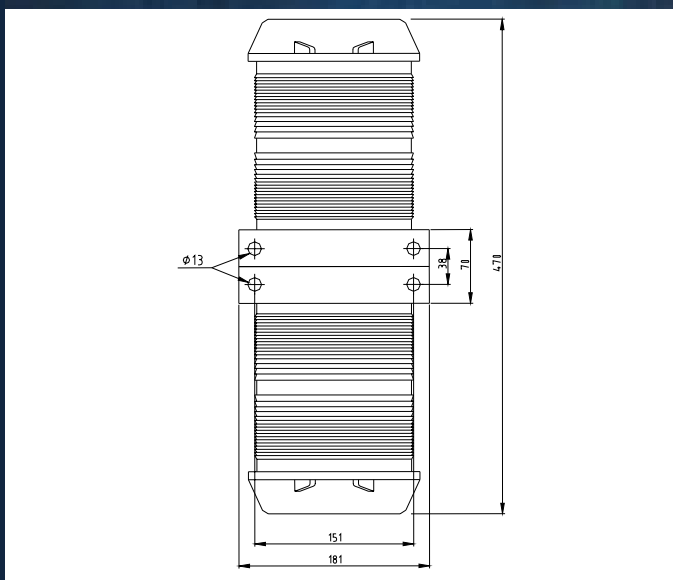

- Input Voltage: 24V, 110V, 220V
- Power Consumption: 50W, 55W, 85W



ISO 9001:2000 certified
Nav. Lights certified by Spanish Maritime Directorate
in compliance with IMO regulations